

## Standard Calibration Charge Accelerometer

### Model AG104A

#### Features:

- Impact and Vibration
- Charge Type Accelerometer
- Positive Voltage Effect

#### Specifications:

##### Dynamic Characteristics

Axes Sensitivity (20±5 deg C)	35 pC/g
Max Transverse Sensitivity	≤ 5 %
Frequency Response (5%)	1 - 5000Hz
Resonance Frequency	18,000 Hz
Temperature Response	See temperature curve
Polarity	Positive
Isolation Resistance	>10 <sup>9</sup> Ω
Capacitance	~ 1200 Pf

##### Environmental/Physical Characteristics

Temperature Range	-20 to +120 ° C
Shock Limit	800g
Temperature Sensitivity	0.1g/°C (0.3Hz)
Magnetic Field Sensitivity	2g/T
Structural Strain Sens.	0.22 mg/μ ε
Weight	30g
Case Material	Stainless steel
Mounting	M5 Screw
Peizo Material	PZT-5
Structure	Center compression
Output Connection	Top L6

Included Accessories	Calibration sheet M5
----------------------	-------------------------

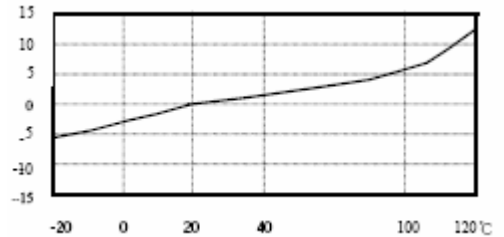
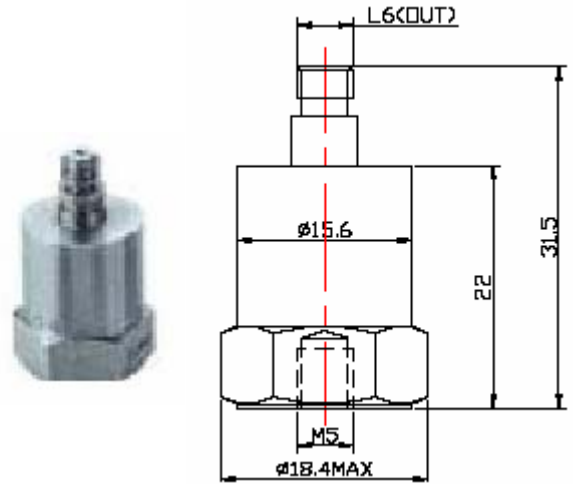

Temperature Curve

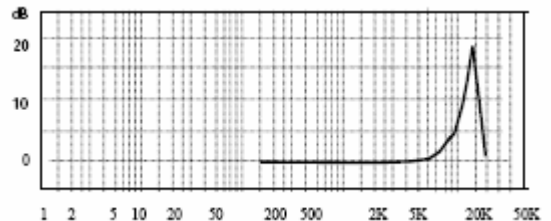

Frequency Response Curve

Product information:  
**KCF Technologies, Inc.**

[www.kcftech.com](http://www.kcftech.com)

112 W. Foster Avenue  
State College, PA 16801

TEL: 814-867-4097

FAX: 814-690-1579

North American Sales & Support:

**Scantek Inc.**

[www.scantekinc.com](http://www.scantekinc.com)

7060 Oakland Mills Road, Suite L  
Columbia, MD 21046

TEL: 410-290-7726

FAX: 410-290-9167