

## Integrated Chip Accelerometer

### Features:

- IC Inside
- Normal Cable
- Industry Measure System

### Model AI186G-1

### Specifications:

#### Dynamic Characteristics

Axes Sensitivity (20±5 deg C)	~100 mV/g
Measurement Range	50 g
Frequency Response (+/-10%)	1 - 4000 Hz
Resonance Frequency	20,000 Hz
Temperature Response	See temperature curve
Polarity	Positive

#### Electrical Specifications

Voltage Supply	+12~+28V <sub>DC</sub>
Current	+2 ~ +10 mA
Max Signal Output	<=5V <sub>P</sub>
Output Impedance	< 100 Ω
Bias Voltage	7 +/- 1 V <sub>DC</sub>
Noise (1~20KHz)	<0.4mg

#### Environmental/Physical Characteristics

Temperature Range	-20 to +120 °C
Shock Limit	4000g
Temperature Sensitivity	8mg/°C
Case Strain Sensitivity	0.2 mg/μ ε
Magnetic Field Sensitivity	1g/T
Weight	65g
Case Material	Stainless Steel
Mounting	1/4" - 28 Screw
Piezo Material	PZT-5
Structure	Cut Mode
Output Connection	5/8" - 24

Included Accessories	Calibration sheet 1/4" - 28 Screw
----------------------	--------------------------------------

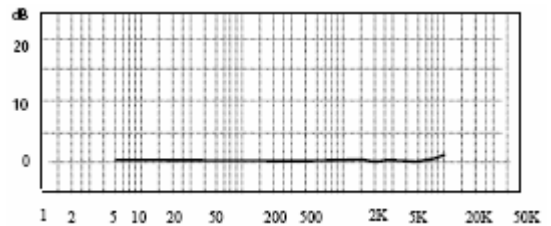
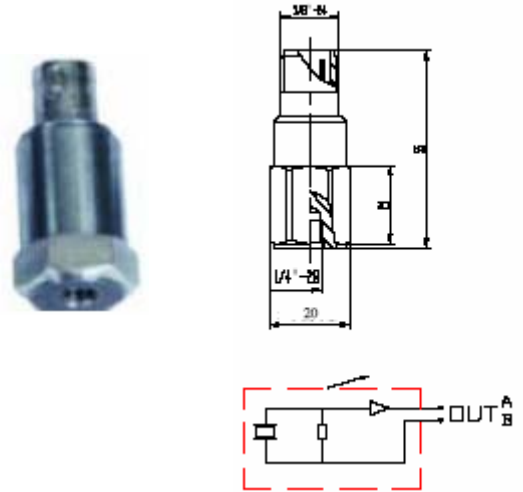

Frequency Response Curve

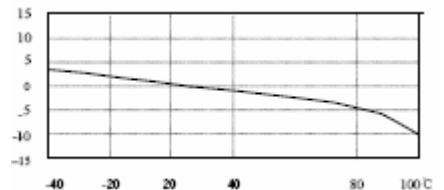

Temperature Curve

Product information:

**KCF Technologies, Inc.**

[www.kcftech.com](http://www.kcftech.com)

119 S. Burrowes St., Suite 605

State College, PA 16801

TEL: 814-867-4097

FAX: 814-238-1875

North American Sales & Support:

**Scantek Inc.**

[www.scantekinc.com](http://www.scantekinc.com)

7060 Oakland Mills Road, Suite L

Columbia, MD 21046

TEL: 410-290-7726

FAX: 410-290-9167