

Low Frequency Accelerometer

Model AS117

Features:

- High Sensitivity
- Low Frequency
- Charge Type Accelerometer

Specifications:

Dynamic Characteristics

Axes Sensitivity (20±5 deg C)	500 pC/g
Max Transverse Sensitivity	<= 5 %
Frequency Response (+/-10%)	0.2 - 3000Hz
Resonance Frequency	10000 Hz
Temperature Response	See temperature curve
Polarity	Positive
Isolation Resistance	>10E9 Ohms
Capacitance	~ 2000 pF

Environmental/Physical Characteristics

Temperature Range	-40 to +150 deg C
Shock Limit	150g
Temperature Sensitivity	3mg/degC (0.3Hz)
Magnetic Field Sensitivity	1g/T
Structural Strain Sens.	0.2 g/microstrain
Weight	50g
Case Material	Stainless steel
Mounting	M5 Screw
Piezo Material	PZT-5
Structure	Cut Mode
Output Connection	L5
Included Accessories	Calibration sheet M5 M5/M8 Screw L5 STYV-1 cable (2m)

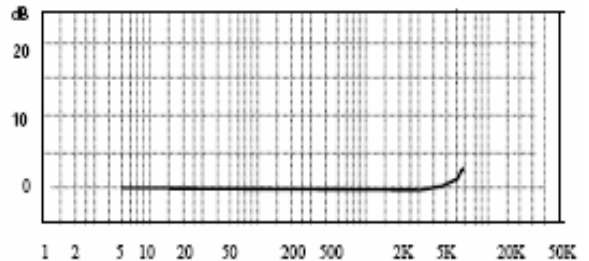
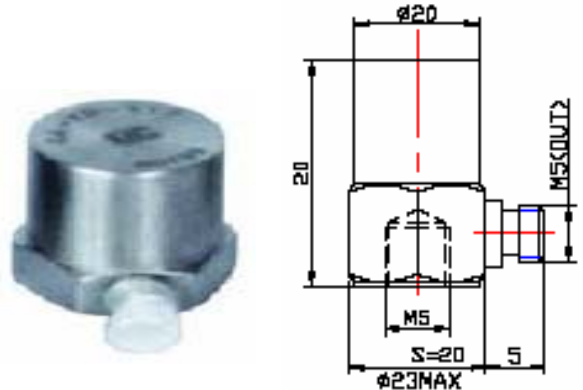

Frequency Response Curve

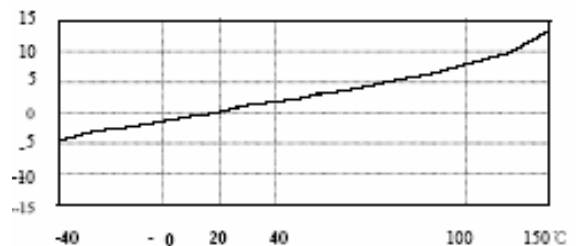

Temperature Curve

Product information:
KCF Technologies, Inc.

www.kcftech.com
112 W. Foster Avenue
State College, PA 16801
TEL: 814-867-4097
FAX: 814-690-1579

North American Sales & Support:
Scantek Inc.

www.scantekinc.com
7060 Oakland Mills Road, Suite L
Columbia, MD 21046
TEL: 410-290-7726
FAX: 410-290-9167